

Family  
**Frankie**

Design – Fredrik Färg & Emma Blanche

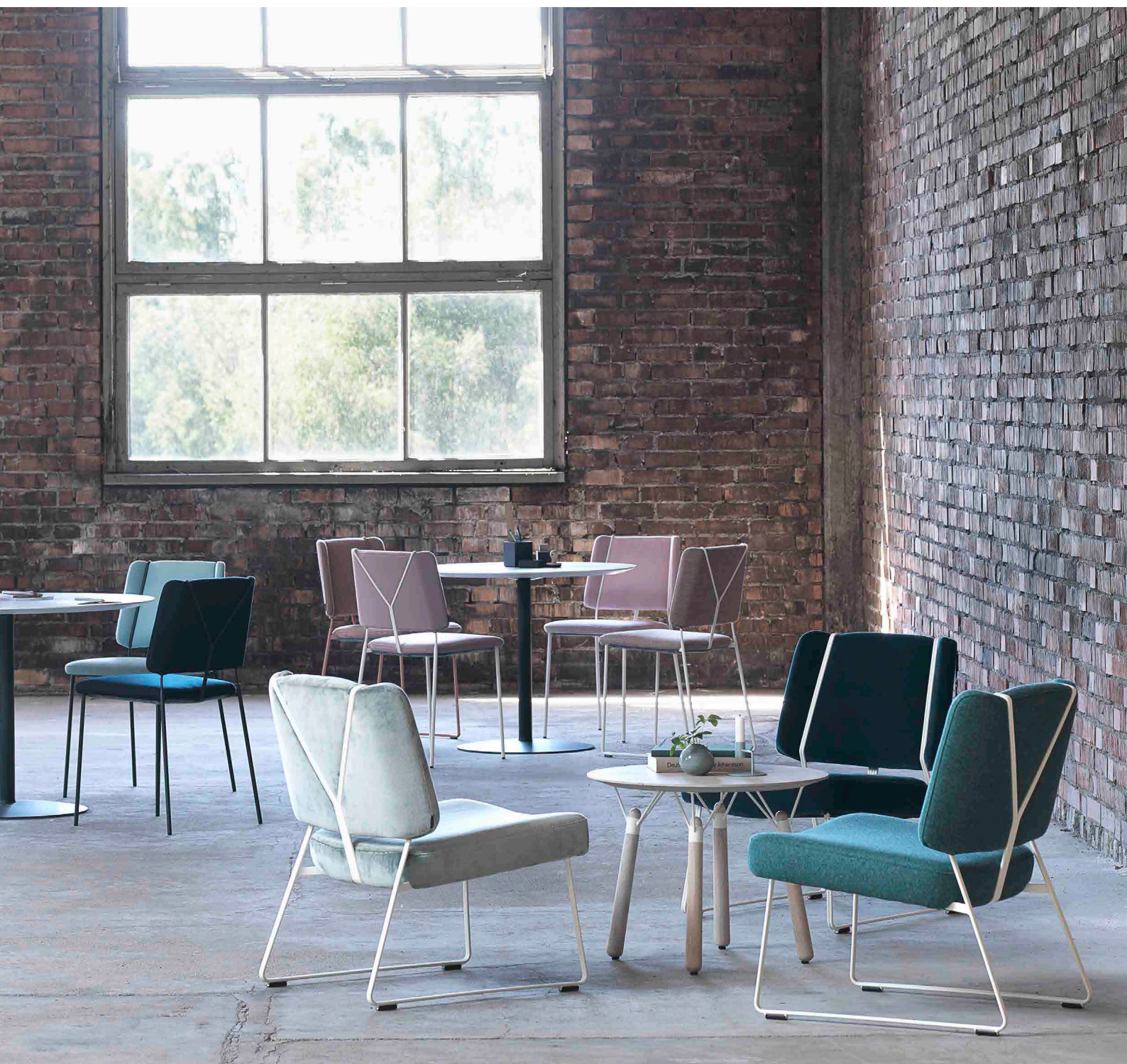

**JOHANSON**



## Introduction

With their special feeling for fashion trends, the design duo Färg & Blanche have created a series inspired by trouser braces. Focus has been on emphasizing the back of their chair, Frankie, and the straps of the braces on the back give this piece of furniture an almost human identity. Frankie has been created for offices and commercial environments.

Frankie Lounge is based on the same design element as the Frankie chair – with the shape of trouser braces incorporated into the back detailing. Instead of the single steel tubes used to create the symbol for Frankie, Frankie Lounge has double tubes that sweep from the front legs to the back, which also cre-

ate a runner frame for the chair. Just like its predecessor the Lounge chair has an upholstered seat and feathered back which provide a high degree of sitting comfort.

“We had the idea for the bar stool when we were examining how we could develop the Frankie chair. We picked out aesthetic elements from the back along with details such as the jointing of the tubing. The resulting shape is like two straps holding and pressing the seat in place forming two clear folds in the seat and creating a soft look. The seat also has the same characteristic curved shape as the back of the Frankie chair with edges that fold inwards on each side,” says Fredrik Färg.



## Designer

Stockholm based design studio Färg & Blanche is known for their experimental stance, where each expression informs the other, they effortlessly move between the exclusive hand made one off and the industrially produced, without ever losing their distinctive touch.



# Models

---



Frankie 08-46



Frankie XL 08-46



Frankie 09-46



Frankie XL 09-46



Frankie BS 80



Frankie BS 65



Frankie Tab



Frankie EC

# Material

---

## Seat - Upholstery materials

Johanson offers a very generous range of fabrics, leather and artificial leather from the most reputable suppliers in the world. Should any other material be desired despite the wide selection, it is also possible to suggest other materials. Johanson does not charge start-up costs for handling non-standard materials.

## Multicolour - Finish RAL

Take part in Johanson's color range, 400 variants of different finishes are offered as standard on steel frames and metal details. Choose from all 192 RAL colors, alternatives are available both as solid finish (gloss 72) or Structure finish which has a matte, slightly textured elegant surface. In addition, 15 RAL colors with pearl finish and chrome are offered.

For all colours see [www.johansondesign.com](http://www.johansondesign.com)

- 192 Solid collection (gloss 72)
- 192 Structure collection (matte, textured surface)
- 15 Pearl finish collection and chrome.



# Accessories

---



## Connector

Frankie 08-base



## Stacking trolley

Stackability for each chair can be found under facts.

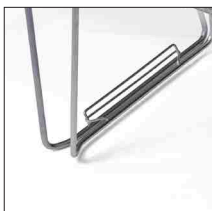

## Connector

Frankie 09-base

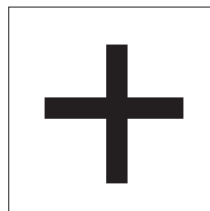

## Extra

Felt gliders  
Stacking protector (standard)

# Facts

---

## Material

The seat is made in moulded CMHR foam (density 65kg) that meets the highest requirements for flammability (CMHR quality). The base is made of finished/lacquered metal.

## Certificate

- Fire certificate (Danak)



## Recycling

All steel parts are recyclable. Before we finish the chrome/lacquer all grease/oil is removed by alkaline wash and then sent for destruction. The lacquering is produced by electrostatic epoxy powder coating that gives a minimum of waste. The electrostatic chrome (chrome 3) is recyclable. The plastic parts that are used are recyclable by grinding. All upholstery and frames of synthetic material are totally without C.F.C. emissions. All glue is water based.

## BIM - objects can be downloaded

at [johansondesign.com](http://johansondesign.com)



## Material declaration

For more information about the product please download material declaration on our website, under Downloads à Product Information at [www.johansondesign.com](http://www.johansondesign.com)

# Facts

---

Measurements cm

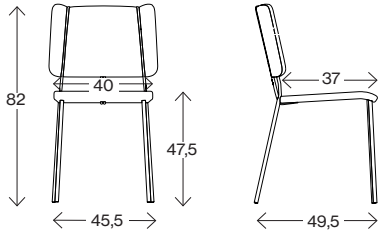

**Frankie 08-46**

Weight (kg)  
Volume (m<sup>3</sup>)

6,0  
0,19



Measurements cm

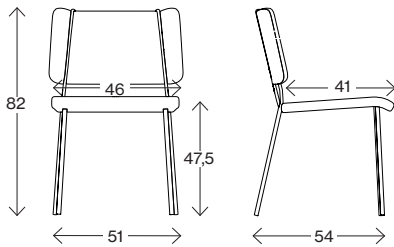

**Frankie XL 08-46**

Weight (kg)  
Volume (m<sup>3</sup>)

7,0  
0,266



Measurements cm

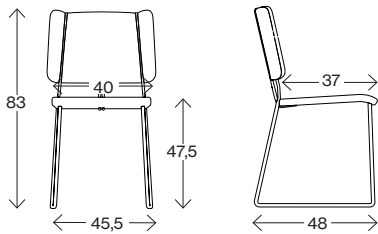

**Frankie 09-46**

Weight (kg)  
Volume (m<sup>3</sup>)

6,0  
0,19



Measurements cm

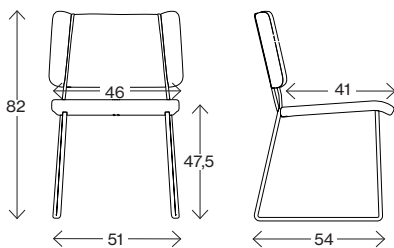

**Frankie XL 09-46**

Weight (kg)  
Volume (m<sup>3</sup>)

7,0  
0,266



# Facts

---

Measurements cm

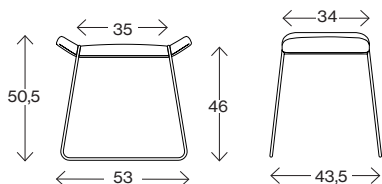

**Frankie Tab**

Weight (kg)  
Volume (m<sup>3</sup>)

5,0  
0,101



Measurements cm

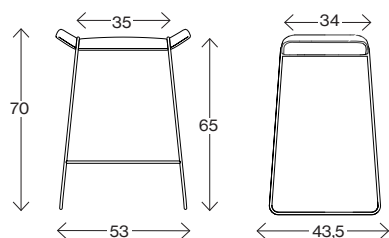

**Frankie BS 65**

Weight (kg)  
Volume (m<sup>3</sup>)

6,0  
0,19

Measurements cm

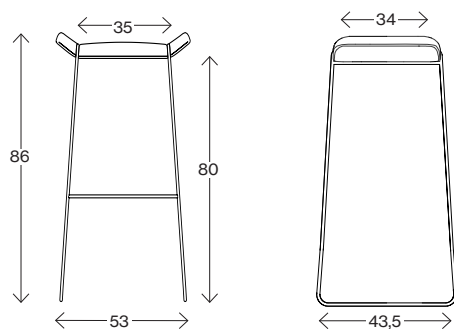

**Frankie BS 80**

Weight (kg)  
Volume (m<sup>3</sup>)

9,0  
0,124

Measurements cm

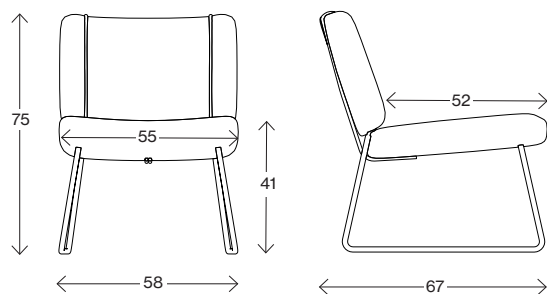

**Frankie EC**

Weight (kg)  
Volume (m<sup>3</sup>)

12,33  
0,512

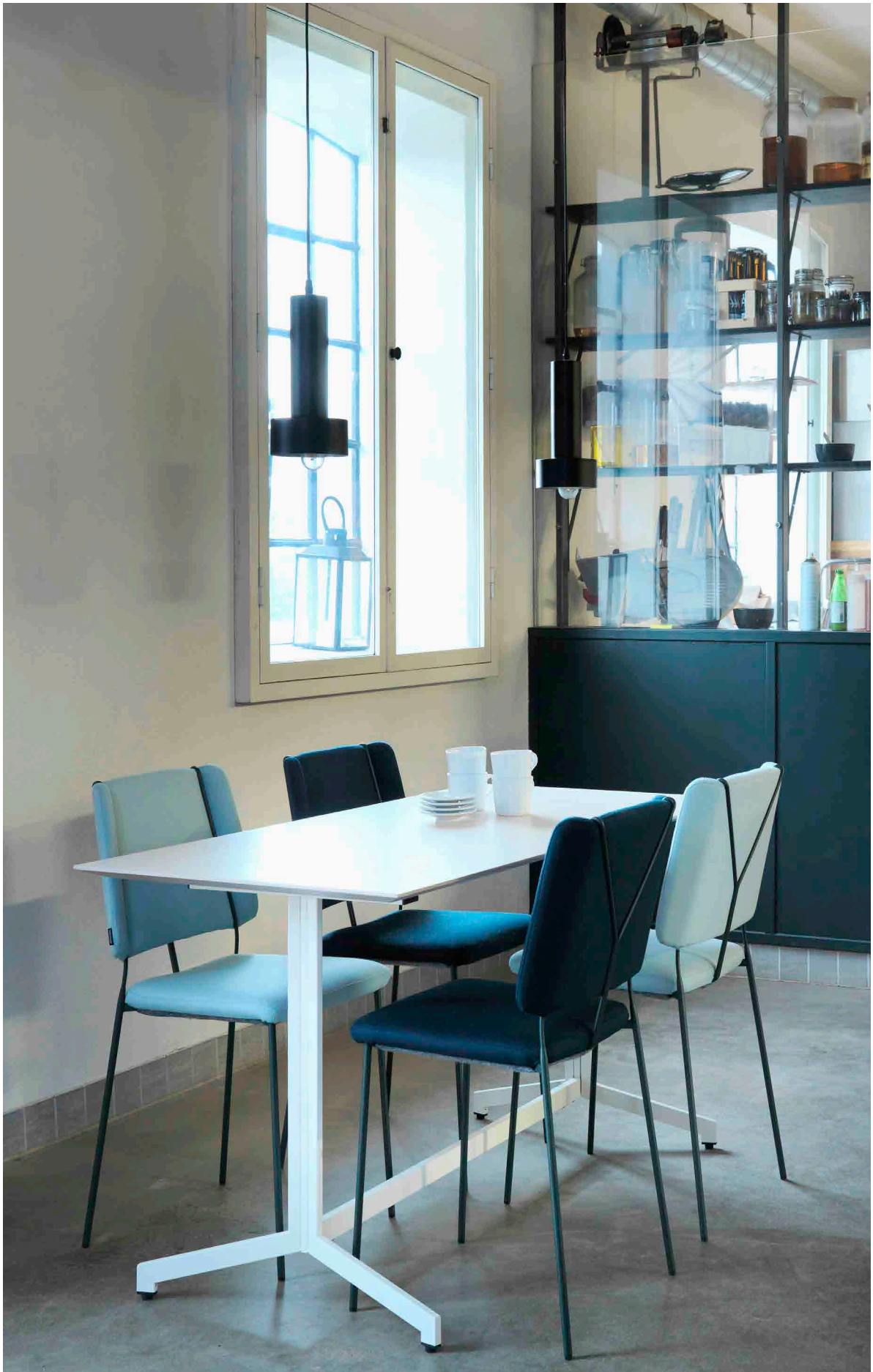







# JOHANSON

---

Johanson Design AB | Anders Anderssons Väg 7 | 285 35 Markaryd | Sweden  
Tel +46-433 725 00 | [www.johansondesign.com](http://www.johansondesign.com)